

INSTALLATION MANUAL & OWNER'S GUIDE



ULTRAVIOLET WATER TREATMENT SYSTEMS

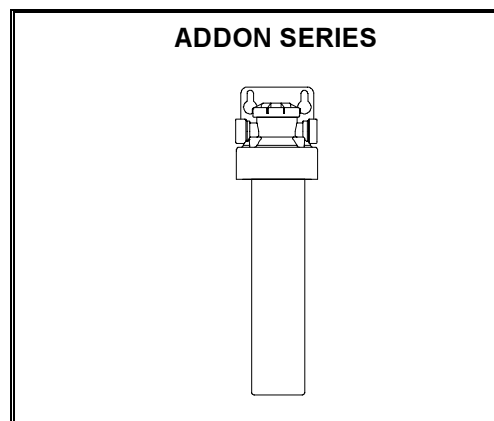
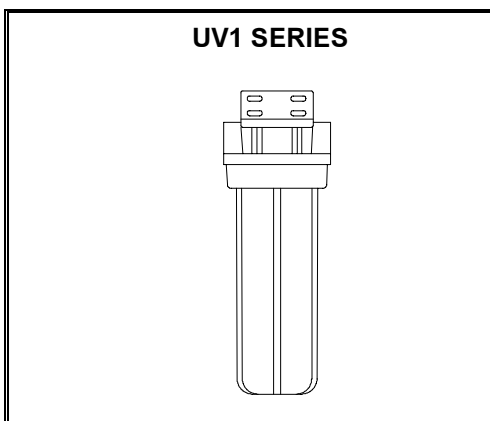
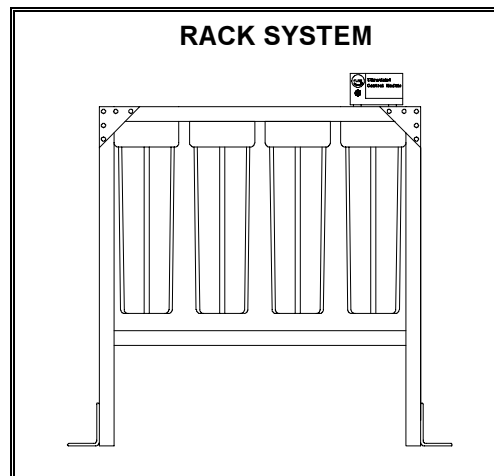
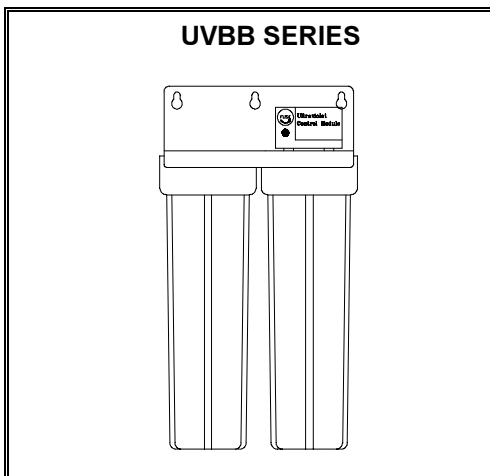
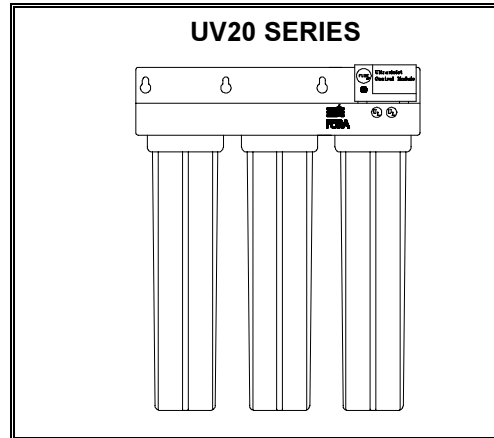
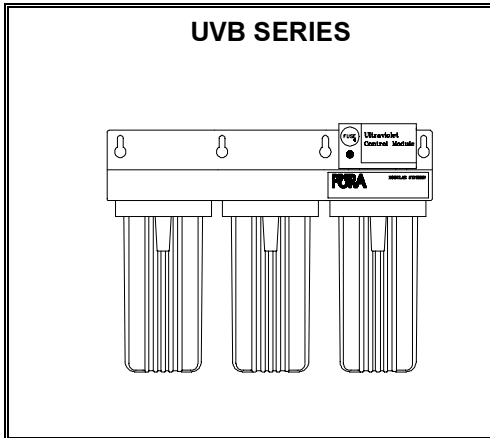
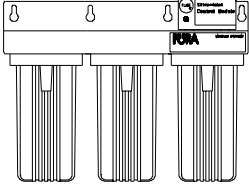
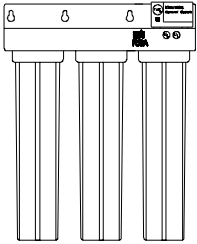
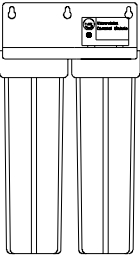
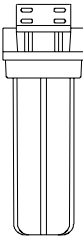



TABLE OF CONTENTS

INTRODUCTION	DESCRIPTIONS AND DEFINITIONS _____	i		
	CONDITIONS FOR USE _____	i		
	ROUTINE MAINTENANCE _____	ii		
	SPECIFICATIONS _____	ii		
    	INSTALLATION	MOUNTING BRACKET AND PLUMBING _____	1	
	UVB SERIES			
	INSTALL QUARTZ SLEEVE AND DISINFECT SYSTEM _____	2		
	INSTALL ULTRAVIOLET LIGHT AND FILTERS _____	2		
	ACTIVATE SYSTEM _____	2		
	SERVICE REQUIREMENTS AND RECOMMENDED INTERVALS _____	2		
	PARTS ILLUSTRATION _____	3		
	PARTS LIST _____	3		
	UV20 SERIES			
	INSTALL QUARTZ SLEEVE AND DISINFECT SYSTEM _____	4		
	INSTALL ULTRAVIOLET LIGHT AND FILTERS _____	4		
	ACTIVATE SYSTEM _____	4		
	SERVICE REQUIREMENTS AND RECOMMENDED INTERVALS _____	4		
	PARTS ILLUSTRATION _____	5		
	PARTS LIST _____	5		
	UVBB SERIES			
	INSTALL QUARTZ SLEEVE AND DISINFECT SYSTEM _____	6		
	INSTALL ULTRAVIOLET LIGHT AND FILTERS _____	6		
	ACTIVATE SYSTEM _____	6		
	SERVICE REQUIREMENTS AND RECOMMENDED INTERVALS _____	6		
	PARTS ILLUSTRATION _____	7		
	PARTS LIST _____	7		
	RACK SYSTEM			8-9
	UV1 SERIES			
	DISINFECT SYSTEM _____	10		
	INSTALL ULTRAVIOLET LIGHT AND FILTERS _____	10		
	ACTIVATE SYSTEM _____	10		
	SERVICE REQUIREMENTS AND RECOMMENDED INTERVALS _____	10		
PARTS ILLUSTRATION _____	11			
PARTS LIST _____	11			
ADDON SERIES				
DISINFECT SYSTEM _____	12			
INSTALL ULTRAVIOLET LIGHT _____	12			
ACTIVATE SYSTEM _____	12			
SERVICE REQUIREMENTS AND RECOMMENDED INTERVALS _____	12			
PARTS ILLUSTRATION _____	13			
PARTS LIST _____	13			
MAINTENANCE	CLEANING AND DISINFECTION _____	14-15		
	FILTER REPLACEMENT _____	15		
	UV LAMP REPLACEMENT _____	15		

INTRODUCTION – DESCRIPTIONS AND DEFINITIONS

You have purchased one of the most technologically advanced Ultraviolet Water Treatment System available anywhere in the world. It has been designed with you, the consumer, in mind. **PURA®** products are lightweight, easy to use, and simple to maintain. **PURA** products will provide you with healthy, clean drinking water for years to come.

WHAT IS ULTRAVIOLET?

Ultraviolet (UV) light from the sun has long been known for its ability to destroy microorganisms. However, it has only been in recent years that equipment producing UV light has been manufactured for residential use.

WARNING: NEVER LOOK DIRECTLY AT A LIGHTED UV LAMP. ULTRAVIOLET RAYS CAN BE HARMFUL TO EYES.

UV energy is produced by low-pressure mercury vapor enclosed in a tubular lamp. While a UV lamp resembles a standard fluorescent lamp, it is similar in appearance only.

Energy produced by the UV lamp has the ability to destroy microorganisms that can live in water. There are five major groups of microorganisms that are altered by a specific spectrum of ultraviolet light: viruses, bacteria, fungi, algae, and protozoa.

When these microbes are exposed to the proper amount of UV energy, their DNA structure is scrambled, and they are unable to reproduce. Since the cell is now sterile or dead, it is no longer a threat.

WHAT IS ACTIVATED CARBON?

Activated carbon has been used for hundreds of years to treat taste, odor, and color problems in water. Activated carbon has been proven to be an excellent media to produce better tasting water and to remove harmful water contaminants at a reasonable cost.

Carbon used for filters may be manufactured from wood, coal, or coconut shells. The raw carbon is ground up and “activated” by heating the granules at a controlled temperature and pressure.

This process causes the carbon granules to expand and create active sites where pollutants can be collected by adsorption. These new sites dramatically increase the total surface area and capacity of each granule.

WHAT IS ADSORPTION?

Adsorption is the physical process where certain water pollutants are attached to the surface of carbon particles as the water flows through the filter. The pollutants are removed from the water and locked into the carbon granule.

Activated carbon is also able to filter out sediment through a process of mechanical filtration. The particles are captured in the spaces between carbon granules.

PURA SYSTEMS

PURA recommends that all UV systems include pre-filters to process the water before it reaches the UV lamp. This will ensure that maximum UV exposure is achieved.

PURA UVB, UV20 and UVBB series offers integrated filters in a single system. These integrated systems use a two-stage filtration process:

First, a string-wound filter removes the suspended solids that may shield the microbes and make it difficult to obtain sufficient UV exposure. Second, an activated carbon filter removes unpleasant tastes and odors.

PURA Ultraviolet Water Treatment Systems are designed for indoor use only.

PURA Systems are designed to provide complete water treatment in a compact, easy-to-use package. Please follow the directions in this Guide exactly when installing your **PURA** System to ensure that it operates correctly.

The UV lamp requires a start-up period of one to two minutes in order to achieve full intensity. Repeated starting of the UV lamp will shorten its life. **Therefore, it is recommended that the UV lamp remain on at all times during use.**

CONDITIONS FOR USE			
Source Water Supply Profile		Chemical Parameters	Max mg/L
Feed Water Pressure [†]	20 – 75psig (138 – 517kPa)	Hardness (CaCO ₃)	< 120 (7 gpg)
Feed Water Temperature	38° – 105°F (3.3°– 40.5°C)	Iron (Fe)	< 0.3
pH Range	6.5 – 9.5	Manganese (Mn)	< 0.05
Total Dissolved Solids	<1500 mg/L	† Water Pressure must not exceed 75 psig (517 kPa) or a pressure regulator must be installed.	
Total Suspended Solids	< 10 mg/L		
Turbidity	< 5 NTU		

ROUTINE MAINTENANCE

It is important that any water treatment system be properly maintained to ensure consistent water quality. The information provided on this page is of a general nature. See Cleaning, Disinfecting, and Routine Maintenance Procedure on Page 14 for detailed information. Refer to Mounting Bracket and System Plumbing Installation Instructions on Page 1, and the appropriate System Assembly and Activation Procedures for detailed information to install your specific PURA system.

Cleaning: The inside of the system and the quartz sleeve should be cleaned each time the filters are changed. Clean all parts (except the filters and electronic parts) with soap and rinse them thoroughly with clean potable water. Dry the inside of the quartz sleeve thoroughly before re-assembling system.

NOTE: Presence of iron or general poor water quality will require frequent inspection and cleaning.

“O” Rings: Lubricate each “O” ring with a silicone based “O” ring lubricant to ensure a proper seal.

NOTE: UV lamp should remain on at all times during use because; repeated starting of UV lamp shortens lamp life, and UV lamp requires a warm up period of 1-2 minutes.

Filter Replacement: Filters will normally last approximately four to six months. Filter life will vary due to water conditions. A reduced flow rate or deteriorating water quality indicates that filters must be changed.

Use only PURA filters. PURA filters are specially designed to work in the ultraviolet disinfection process. Use of non-PURA filters voids the warranty.

CAUTION: Use care when changing the filters to avoid breaking the quartz sleeve.

UV Lamp Replacement: Lamps must be changed every twelve months. While UV lamps rarely burn out, they do lose their disinfection power. **Use only PURA UV lamps as they are specifically designed for the PURA system to deliver high quality drinking water.**

PURA ULTRAVIOLET SPECIFICATIONS					
Model	Shipping Weight lbs. (kg)	Dimensions [◊] Inches (Centimeters) Height x Width x Depth	Flow Rate Gallons Per Minute Liters per Minute	Lamp Type & Power Used Watts	Inlet/ Outlet
UVB1	10.0 lbs. (4.5 kg)	15.0" (38.1 cm) x 5.5" (14.0 cm) x 5.5" (14.0 cm)	2 gpm (7.6 L/min)	UV Lamp #11 14 Watts	3/8" NPT [†]
UVB2	15.0 lbs. (6.8 kg)	15.0" (38.1 cm) x 11.0" (27.9 cm) x 5.5" (14.0 cm)			
UVB3	24.0 lbs. (10.9 kg)	15.0" (38.1 cm) x 16.0" (40.6 cm) x 5.5" (14.0 cm)			
UV20-1	16.0 lbs. (7.3 kg)	25.0" (63.5 cm) x 5.5" (14.0 cm) x 5.5" (14.0 cm)	10 gpm (38 L/min)	UV Lamp #20 22 Watts	3/4" NPT [†]
UV20-2	24.0 lbs. (10.9 kg)	25.0" (63.5 cm) x 11.0" (27.9 cm) x 5.5" (14.0 cm)	8 gpm (30 L/min)		
UV20-3	32.0 lbs. (14.5 kg)	25.0" (63.5 cm) x 16.0" (40.6 cm) x 5.5" (14.0 cm)			
UVBB-1	20.0 lbs. (9.1 kg)	29.5" (74.9 cm) x 7.5" (19.0 cm) x 9.0" (22.9 cm)	15 gpm (57 L/min)	UV Lamp #20 22 Watts	1-1/2" NPT [†]
UVBB-2	35.0 lbs. (15.9 kg)	28.0" (71.1 cm) x 15.0" (38.1 cm) x 9.0" (22.9 cm)			
UVBB-3	53 lbs. (24.0 kg)	28.0" (71.1 cm) x 23.0" (58.4 cm) x 9.0" (22.9 cm)			
UV1	7.0 lbs. (3.2 kg)	13.5" (34.3 cm) x 5.0" (12.7 cm) x 5.0" (12.7 cm)	1 gpm (3.8 L/min)	UV Lamp #10 10 Watts	1/2" NPT [†]
UV A/O-1	5.0 lbs. (2.3 kg)	12.0" (30.5 cm) x 4.0" (10.2 cm) x 3.5" (8.9 cm)	1 gpm (3.8 L/min)	UV Lamp #10 10 Watts	3/8" QC [‡]
UV A/O-3	7.0 lbs. (3.2 kg)	22.5" (57.2 cm) x 4.0" (10.2 cm) x 3.5" (8.9 cm)	3 gpm (11.4 L/min)	UV Lamp #20 22 Watts	

[†] Female thread as recognized by United States *National Pipe Thread*.

[‡] Push-in Quick Connectors or Quick Connectors (QC).

[◊] All dimensions of system do not include inlet/outlet piping connections and are rounded up to the nearest 1/2".

**WARNING: NEVER LOOK DIRECTLY AT A LIGHTED UV LAMP.
ULTRAVIOLET RAYS CAN BE HARMFUL TO EYES.
ALWAYS SHUT OFF WATER TO SYSTEM AND DISCONNECT POWER WHEN SERVICING.
ASSEMBLY IS REQUIRED BEFORE INSTALLATION. FRAGILE PARTS INSIDE.
FOLLOW INSTRUCTIONS CAREFULLY!**

The system must be installed in accordance with applicable city, country, and local plumbing codes.

PURA products are designed to provide years of trouble-free service if properly maintained.
Retain these instructions for future reference.

MOUNTING BRACKET AND SYSTEM PLUMBING INSTALLATION

This Guide covers installation and maintenance of a basic “generic” system. Installer determines configuration of each system and must adapt these instructions to meet the specific requirements for that configuration. Specific component and assembly information is provided only for components that are unique to PURA systems. All inter-component connections use standard plumbing components and tools.

INSTALL MOUNTING BRACKET

CAUTION: Do not use any damaged component.
If damage is found, contact your dealer before proceeding.

1. Unpack boxes and verify that all required components have been received (see Preparation section for your particular series).
2. Inspect each component for damage.
3. Determine location for installation of the UV system:
 - a. The **PURA** UV System should be installed with the sumps oriented vertically.

CAUTION: The UV system may be installed horizontally, but the quartz sleeve will be in a position that makes it susceptible to breakage.

- b. Mounting point should allow sufficient room above and below UV system to service the sumps and UV lamp without removing the UV system.

The minimum space is:

UVB: 11” (above and below)

UV20, UVBB: 20” (above and below)

UV1: 10” (above and below)

ADDON: 10” or 20” (above) by model

4. For ease of mounting, reduce the weight of the larger systems by removing the sumps and filters prior to installing the mounting bracket.
5. Select a location and install the mounting bracket using the provided screws.

INSTALL SYSTEM PLUMBING

CAUTION: Water pressure must not exceed 75 psig (517 kPa) or a pressure regulator must be used.

CAUTION: Do not install pump on outlet side of system as damage to the quartz sleeve may occur. If pump is required, install it on inlet side of system and verify output pressure does not exceed 75 psig (517 kPa).

CAUTION: Warranty is void if the unit is used with pressure exceeding 75 psig (517 kPa). Higher pressures may damage equipment and may not allow for proper exposure time with UV lamp or both.

CAUTION: The system will not function properly if water flow is reversed. See the Exploded Schematic for your model on the following pages to ensure proper flow direction.

1. Turn off source water supply.

CAUTION: PURA recommends using only plastic fittings to connect the inlet and outlet ports of the PURA system. Use of metal male fittings inside of plastic female threaded heads voids the warranty.

CAUTION: Do not over tighten fittings connected to inlet/outlet ports of the PURA system.

2. Connect inlet of UV system to source water supply using proper fittings and thread sealing tape.
3. Connect outlet of UV system to water distribution lines using proper fittings and thread sealing tape.
4. See appropriate System Assembly and Activation Procedures for your system to complete installation.

UVB SERIES - SYSTEM ASSEMBLY AND ACTIVATION PROCEDURES

PREPARATION – INSPECT ALL PARTS

NOTE: Read Mounting Bracket and System Plumbing Installation instructions on Page 1 and all instructions on this page before installing system.

UVB SERIES
UVB Ultraviolet System Ultraviolet Lamp #11 (in packing tube) Quartz Sleeve #11 (in packing tube) Mounting Screws (2-4 pieces, varies with model) Installation Manual and Owners Guide Sump Wrench #10/20

NOTE: See Page 3 for UVB detailed parts breakdown. Refer to the label affixed to the mounting bracket to identify filter(s) to be installed with UV module.

INSTALL QUARTZ SLEEVE AND DISINFECT SYSTEM

CAUTION: QUARTZ SLEEVE IS VERY FRAGILE!
 For safety, wear a protective glove when handling quartz sleeve. Do not touch quartz sleeve or UV lamp with bare hands. Fingerprints will reduce the effectiveness of the light.

NOTE: All Items refer to Figure 1.

1. Remove Sump (Item 1) from UV Head (Item 5).

NOTE: Do not remove protective plastic bag from quartz sleeve until so instructed.

2. Remove Quartz Sleeve (Item 17) from packing tube. While holding middle of quartz sleeve with one hand, slide protective bag with other hand to expose open end.
3. Place a small amount of silicone based “O” ring lubricant on the outside of the open end of the quartz sleeve only on the area that will engage with the “O” ring.

CAUTION: Apply even pressure to push the quartz sleeve into the UV head. To avoid breakage, make sure quartz sleeve goes in straight by pushing it with a slight twisting motion.

4. Insert quartz sleeve into the UV head. As quartz sleeve passes both “O” Rings (Item 15), resistance will be felt. Remove protective bag from quartz sleeve.
5. Remove EPCB™ Carbon Filter (Item 3) and EPCB™ Sleeve (Item 24) from sump and set aside.
6. **For UVB2 and UVB3 Models only:** Remove Sump (Item 1) from Filter Head (Item 20). Remove Filters (Items 21 and 23) from sump and set aside.
7. Disinfect the system (Pages 14-15, Steps 1-7).

INSTALL ULTRAVIOLET LIGHT AND FILTERS

1. Remove Sump (Item 1) from UV Head (Item 5).

NOTE: Wipe all fingerprints and excessive lubricant from quartz sleeve with isopropyl alcohol.

2. Install EPCB™ Sleeve (Item 24) into EPCB™ Carbon Filter (Item 3) as shown in Figure 1.

3. Insert filter/sleeve assembly into sump as shown in Figure 1 with both Filter Gaskets (Item 4) in place.

CAUTION: TIGHTEN SUMPS BY HAND ONLY. Do not use tools as they will over-tighten and may damage sump. Take care not to cut or pinch “O” Rings (Item 2). Use sump wrench for removal only.

4. Being careful not to dislodge quartz sleeve, install sump with filter/sleeve assembly onto UV head.
5. **For UVB2 & UVB3 Models only:** Remove Sump (Item 1) from Filter Head (Item 20). Install Filters (Items 21 and 23) as shown in Figure 1. Install sump onto filter head.

CAUTION: DO NOT INSTALL A DAMAGED LAMP

6. Remove UV Control Module (Item 10) from Mounting Bracket (Item 6, 6A, or 6B) by removing four Screws (Item 11).

NOTE: Hold UV lamp by ceramic ends only. Do not touch the glass. Clean with isopropyl alcohol if necessary.

1. Remove UV Lamp (Item 16) from packing tube and inspect it for damage. If damage is found, contact the dealer for a replacement.
2. Connect UV lamp into four-pin socket located at the bottom of UV Control Module (Item 10).
3. Verify Safety Plunger Rod (Item 18) is in place.

NOTE: System with Light-Out Circuit (LOC) does not have a safety plunger rod.

4. Carefully insert the UV control module with UV lamp through mounting bracket into the quartz sleeve and replace screws removed in Step 6.

ACTIVATE SYSTEM

CAUTION: Verify that inlet and outlet ports are connected to appropriate inlet/outlet pipes (see Figure 1).

1. Plug system into an electrical outlet. If the LED Indicator (Item 8) does not light up within one minute, verify UV lamp is securely plugged into UV control module and safety plunger rod is in place (see Note in Step 9 above). It is normal for the LED indicator to flicker slightly.

NOTE: The UV lamp should remain on at all times during use because; repeated starting of UV lamp shortens lamp life, and UV lamp requires a warm up period of 1-2 minutes.

2. Turn on water supply and check for leaks.
3. Flush system, connectors, and water lines for several minutes to remove carbon fines.

NOTE: When an ultraviolet water treatment system is unused for several hours, water within system could become warm. This is a normal condition. To cool the water, dispense water from system.

NOTE: System is now ready for use.

Service Requirements	Recommended Service Intervals
To ensure the system operates at its optimum level, certain routine maintenance must be performed. Frequency of maintenance performance will depend on source water quality and level of system usage. CLEAN: Each time filters are replaced. DISINFECT: At least once a year.	UV Lamp #11: Change Annually Quartz Sleeve #11: Clean when changing filters. Replace only if damaged or cannot be cleaned by non-abrasive methods. Filters: Normal life 4-6 months. Filter life will vary due to water conditions. A reduced flow rate or deteriorating water quality indicates that filters must be changed.

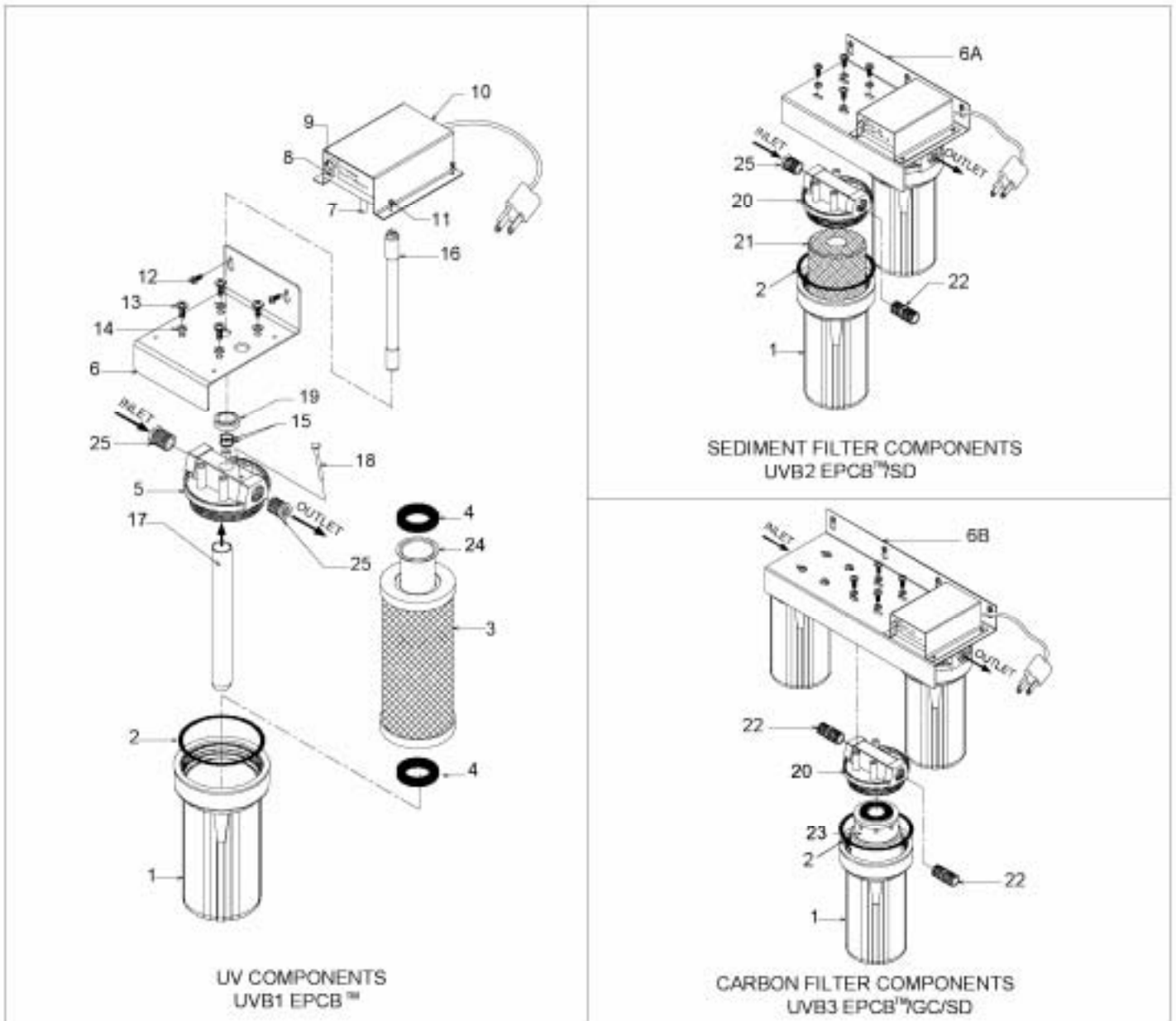

Figure 1 Exploded Schematic, PURA UVB Series

Parts List - UVB Series								
Item	Description	Part No.	Item	Description	Part No.	Item	Description	Part No.
1	Sump, #10	153001-06	7	Switch, Safety	----	17	Sleeve Quartz #11, with "O" Rings	36003034
2	"O" Ring, Sump #10/20	151120	8	Indicator, LED	----	18	Rod, Safety Plunger	22401015
3	Filter, Carbon EPCB™ 10"	33004030	9	Fuse, 1A Type 3AG	31000006	19	Spacer, Bushing #10/20	22401016
4	Gasket, c/w Filter	----	10	Module, UV Control #11	40200116†	20	Head, Filter 3/4" #10/20	154017
5	Head UV #10/20	36005701	11	Screw, 6/32 x 3/8"	32701063	21	Filter, Sediment 10" 5 micron	33003051
6	Mounting Bracket, 1 Sump	31910101	12	Screw, #10 x 3/4"	32701006	22	Nipple, 3/4"	33601023
6A	Mounting Bracket, 2 Sump	31910201	13	Screw, #14 x 1"	32701060	23	Filter, GC 10" 5 micron	33004024
6B	Mounting Bracket, 3 Sump	31910301	14	Washer, #14 Nylon	32800031	24	Sleeve, Teflon	30120506
			15	"O" Ring, Quartz Sleeve, Standard (2)	34202021	25	Bushing, 3/4" x 3/8"	33300017
			16	Lamp, UV #11	36002017	n/s‡	Wrench, Sump #10/20	150295

† Consult Factory to determine part number for applications other than 120V/60hz ‡ not shown

UV20 SERIES - SYSTEM ASSEMBLY AND ACTIVATION PROCEDURES

PREPARATION – INSPECT ALL PARTS

NOTE: Read Mounting Bracket and System Plumbing Installation instructions on Page 1 and all instructions on this page before installing system.

UV20 SERIES
UV20 Ultraviolet System Ultraviolet Lamp #20 (in packing tube) Quartz Sleeve #20 (in packing tube) Mounting Screws (2-4 pieces, varies with model) Installation Manual and Owners Guide Sump Wrench #10/20

NOTE: See Page 5 for UV20 detailed parts breakdown. Refer to the label affixed to the mounting bracket to identify filter(s) to be installed with UV module.

INSTALL QUARTZ SLEEVE AND DISINFECT SYSTEM

CAUTION: QUARTZ SLEEVE IS VERY FRAGILE!

For safety, wear a protective glove when handling quartz sleeve. Do not touch quartz sleeve or UV lamp with bare hands. Fingerprints will reduce the effectiveness of the light.

NOTE: All Items refer to Figure 2.

1. Remove Sump (Item 1) from UV Head (Item 5).

NOTE: Do not remove protective plastic bag from quartz sleeve until so instructed.

2. Remove Quartz Sleeve (Item 17) from packing tube. While holding middle of quartz sleeve with one hand, slide protective bag with other hand to expose open end.
3. Place a small amount of silicone based “O” ring lubricant on the outside of the open end of the quartz sleeve only on the area that will engage with the “O” ring.

CAUTION: Apply even pressure to push the quartz sleeve into the UV head. To avoid breakage, make sure quartz sleeve goes in straight by pushing it with slight twisting motion.

4. Insert quartz sleeve into the UV head. As quartz sleeve passes both “O” Rings (Item 15), resistance will be felt. Remove protective bag from quartz sleeve.
5. **For UV20-2 and UV20-3 Models only:** Remove Sump (Item 1) from Filter Head (Item 20). Remove Filters (Items 21 and 23) from sump and set aside.
6. Disinfect the system (Pages 14-15, Steps 1-7).

INSTALL ULTRAVIOLET LIGHT AND FILTERS

1. Remove Sump (Item 1) from UV Head (Item 5).

NOTE: Wipe all fingerprints and excessive lubricant from quartz sleeve with isopropyl alcohol.

2. Verify Stainless Steel Channeling Sleeve (Item 3) and Sleeve Gasket (Item 4) are in sump as shown in Figure 2.

CAUTION: TIGHTEN SUMPS BY HAND ONLY. Do not use tools as they will over-tighten and may damage sump. Take care not to cut or pinch “O” Rings (Item 2). Use sump wrench for removal only.

3. Being careful not to dislodge quartz sleeve, install sump with stainless steel channeling sleeve and sleeve gasket onto UV head.
4. **For UV20-2 & UV20-3 Models only:** Remove Sump (Item 1) from Filter Head (Item 20). Install Filters (Items 21 and 23) as shown in Figure 2. Install sump onto filter head.

CAUTION: DO NOT INSTALL A DAMAGED LAMP

5. Remove UV Control Module (Item 10) from Mounting Bracket (Item 6, 6A, or 6B) by removing four Screws (Item 11).

NOTE: Hold UV lamp by ceramic ends only. Do not touch glass. Clean it with isopropyl alcohol if necessary.

6. Remove UV Lamp (Item 16) from packing tube and inspect it for damage. If damage is found, contact the dealer for a replacement.
7. Connect UV lamp into four-pin socket located at the bottom of UV control module.
8. Verify Safety Plunger Rod (Item 18) is in place.

NOTE: System with Light-Out Circuit (LOC) does not have a safety plunger rod.

9. Carefully insert the UV control module with UV lamp through mounting bracket into the quartz sleeve and replace screws removed in Step 5.

ACTIVATE SYSTEM

CAUTION: Verify that inlet and outlet ports are connected to appropriate inlet/outlet pipes (see Figure 2).

1. Plug system into an electrical outlet. If the LED Indicator (Item 8) does not light up within one minute, verify UV lamp is securely plugged into UV control module and safety plunger rod is in place (see Note in Step 8 above). It is normal for the LED indicator to flicker slightly.

NOTE: The UV lamp should remain on at all times during use because; repeated starting of UV lamp shortens lamp life, and UV lamp requires a warm up period of 1-2 minutes.

2. Turn on water supply and check for leaks.
3. Flush system, connectors, and water lines for several minutes to remove carbon fines.

NOTE: When an ultraviolet water treatment system is unused for several hours, water within system could become warm. This is a normal condition. To cool the water, dispense water from system.

NOTE: System is now ready for use.

Service Requirements	Recommended Service Intervals
To ensure the system operates at its optimum level, certain routine maintenance must be performed. Frequency of maintenance performance will depend on source water quality and level of system usage. CLEAN: Each time filters are replaced. DISINFECT: At least once a year.	UV Lamp #20: Change Annually Quartz Sleeve #20 and Channeling Sleeve: Clean when changing filters. Replace only if damaged or cannot be cleaned by non-abrasive methods. Filters: Normal life 4-6 months. Filter life will vary due to water conditions. A reduced flow rate or deteriorating water quality indicates that filters must be changed.

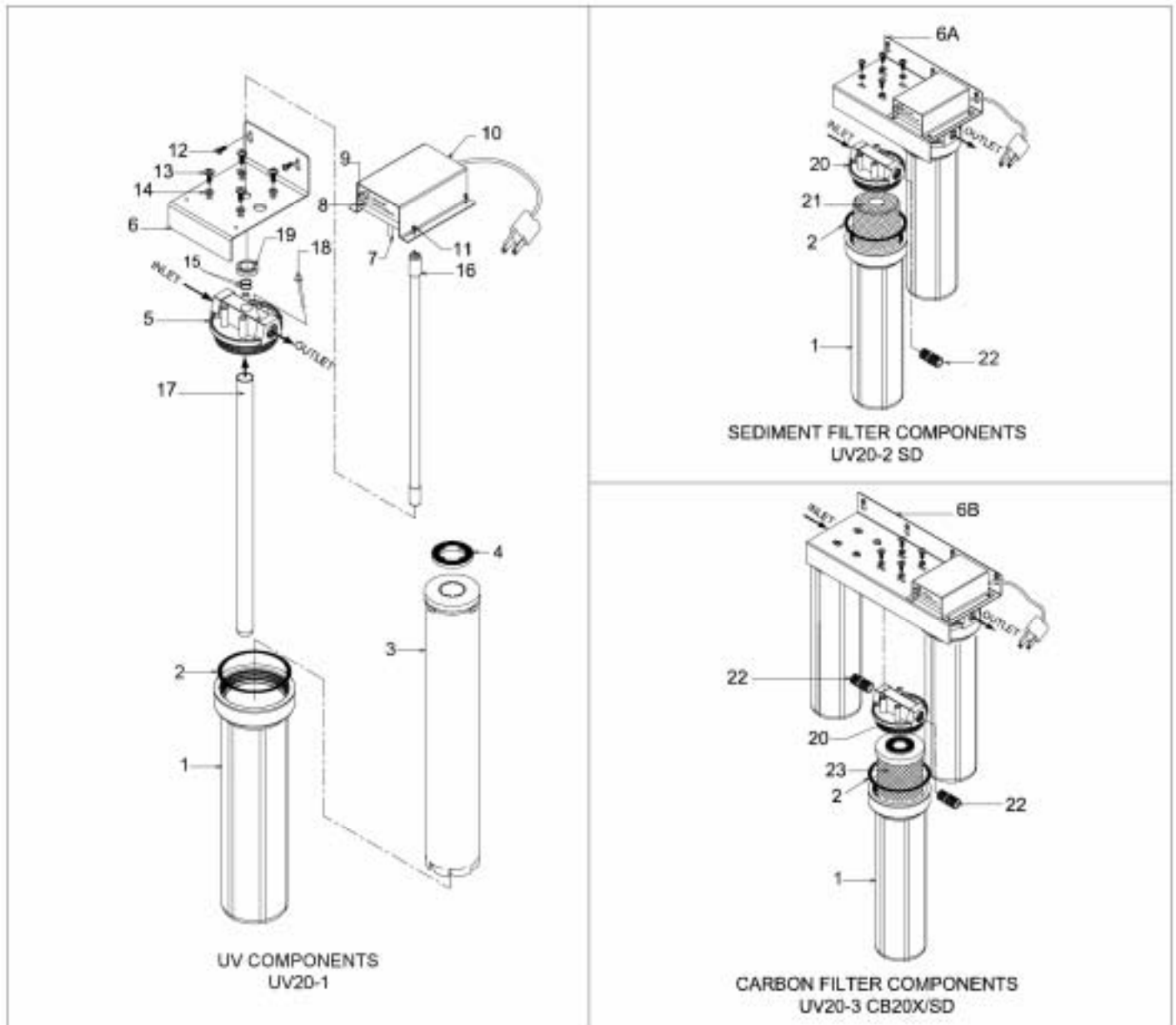

Figure 2 Exploded Schematic, PURA UV20 Series

Parts List - UV20 Series								
Item	Description	Part No.	Item	Description	Part No.	Item	Description	Part No.
1	Sump, #20	153013	7	Switch, Safety	----	16	Lamp UV #20	36002018
2	"O" Ring, Sump #10/20	151120	8	Indicator, LED	----	17	Sleeve Quartz #20, with "O" Rings	36003035
3	Sleeve, Channeling S/S, #20	44301007	9	Fuse, 1A Type 3AG	31000006	18	Rod, Safety Plunger	22401015
4	Gasket, Sleeve	36099205	10	Module, UV Control #20	40200116 [†]	19	Spacer, Bushing #10/20	22401016
5	Head UV #10/20,	36005701	11	Screw, 6/32 x 3/8"	32701063	20	Head, Filter 3/4" #10/20	154017
6	Mounting Bracket, 1 Sump	31910101	12	Screw, #10 x 3/4"	32701006	21	Filter, Sediment 20" 5 micron	33003033
6A	Mounting Bracket, 2 Sump	31910201	13	Screw, #14 x 1"	32701060	22	Nipple, 3/4"	33601023
6B	Mounting Bracket, 3 Sump	31910301	14	Washer, #14 Nylon	32800031	23	Filter, Carbon Block 20" EPM 10 micron	33004022
			15	"O" Ring, Quartz Sleeve, Standard (2)	34202021	n/s [‡]	Wrench, Sump #10/20	150295

[†] Consult Factory to determine part number for applications other than 120V/60hz [‡] not shown

UVBB SERIES - SYSTEM ASSEMBLY AND ACTIVATION PROCEDURES

PREPARATION – INSPECT ALL PARTS

NOTE: Read Mounting Bracket and System Plumbing Installation instructions on Page 1 and all instructions on this page before installing system.

UVBB SERIES
UVBB Ultraviolet System Ultraviolet Lamp #20 (in packing tube) Quartz Sleeve #22 (in packing tube) Mounting Screws (2-4 pieces, varies with model) Installation Manual and Owners Guide Sump Wrench #20BB

NOTE: See Page 7 for UVBB detailed parts breakdown. Refer to label affixed to the mounting bracket to identify filter(s) to be installed with UV module.

INSTALL QUARTZ SLEEVE AND DISINFECT SYSTEM

CAUTION: QUARTZ SLEEVE IS VERY FRAGILE!
 For safety, wear a protective glove when handling quartz sleeve. Do not touch quartz sleeve or UV lamp with bare hands. Fingerprints will reduce the effectiveness of the light.

NOTE: All Items refer to Figure 3.

1. Remove UV Sump (Item 1) from UV Head (Item 5).

NOTE: A band of Red Tape (Item 23) is affixed to quartz sleeve approximately 3" from the top. Do not remove this tape until so instructed. Do not remove protective plastic bag from quartz sleeve until so instructed.

2. Remove Quartz Sleeve (Item 17) from packing tube. While holding middle of quartz sleeve with one hand, slide protective bag with other hand to expose open end.
3. Place a small amount of silicone based "O" ring lubricant on the outside of the open end of the quartz sleeve only on the area that will engage with the "O" ring.

CAUTION: Apply even pressure to push the quartz sleeve into Quartz Adapter Sleeve (Item 4). To avoid breakage, make sure quartz sleeve goes in straight by pushing it with a slight twisting motion.

4. Insert quartz sleeve into quartz adapter sleeve until the top of red tape meets the bottom of the quartz adapter sleeve.

NOTE: Quartz Adapter Sleeve (Item 4) is factory installed into the UV Head (Item 5).

5. Remove Red Tape (Item 23) and protective bag from quartz sleeve.

NOTE: Wipe all fingerprints and excessive lubricant from quartz sleeve with isopropyl alcohol.

6. **For UVBB-2 and UVBB-3 Models only:** Remove Sump (Item 1) from Filter Head (Item 20). Remove Filters (Items 21 and 22) from sump and set aside.
7. Disinfect the system (Pages 14-15, Steps 1-7).

INSTALL ULTRAVIOLET LIGHT AND FILTERS

CAUTION: TIGHTEN SUMPS BY HAND ONLY. Do not use tools as they will over-tighten and may damage sump. Take care not to cut or pinch "O" Rings (Item 2). Use sump wrench for removal only.

1. **For UVBB-2 and UVBB-3 Models only:** Remove Sump (Item 1) from Filter Head (Item 20). Install Filters (Items 21 and 22) as shown in Figure 3. Install sump onto filter head.

CAUTION: DO NOT INSTALL A DAMAGED LAMP

2. Remove UV Control Module (Item 10) from Mounting Bracket (Item 6, 6A, or 6B) by removing four Screws (Item 11).

NOTE: Hold UV lamp by ceramic ends only. Do not touch the glass. Clean glass with isopropyl alcohol if necessary.

3. Remove UV Lamp (Item 16) from packing tube and inspect it for damage. If damage is found, contact the dealer for a replacement.
4. Connect UV lamp into four-pin socket that is connected to the UV control module by a cable that allows for correct insertion depth.
5. Carefully insert the UV control module with UV lamp through mounting bracket into the quartz sleeve making sure the cable does not twist or curl. Replace screws removed in Step 2.

ACTIVATE SYSTEM

CAUTION: Verify that inlet and outlet ports are connected to appropriate inlet/outlet pipes (see Figure 3).

1. Plug system into an electrical outlet. If the LED Indicator (Item 8) does not light up within one minute, verify UV lamp is securely plugged into UV control module. It is normal for the LED indicator to flicker slightly.

NOTE: The UV lamp should remain on at all times during use because; repeated starting of UV lamp shortens lamp life, and UV lamp requires a warm up period of 1-2 minutes.

2. Turn on water supply and check for leaks.
3. Flush system, connectors, and water lines for several minutes to remove carbon fines.

NOTE: When an ultraviolet water treatment system is unused for several hours, water within system could become warm. This is a normal condition. To cool the water, dispense water from system.

NOTE: System is now ready for use.

Service Requirements	Recommended Service Intervals
To ensure the system operates at its optimum level, certain routine maintenance must be performed. Frequency of maintenance performance will depend on source water quality and level of system usage. CLEAN: Each time filters are replaced. DISINFECT: At least once a year	UV lamp #20: Change Annually Quartz Sleeve #22: Clean when changing filters. Replace only if damaged or cannot be cleaned by non-abrasive methods. Filters: Normal life 4-6 months. Filter life will vary due to water conditions. A reduced flow rate or deteriorating water quality indicates that filters must be changed.

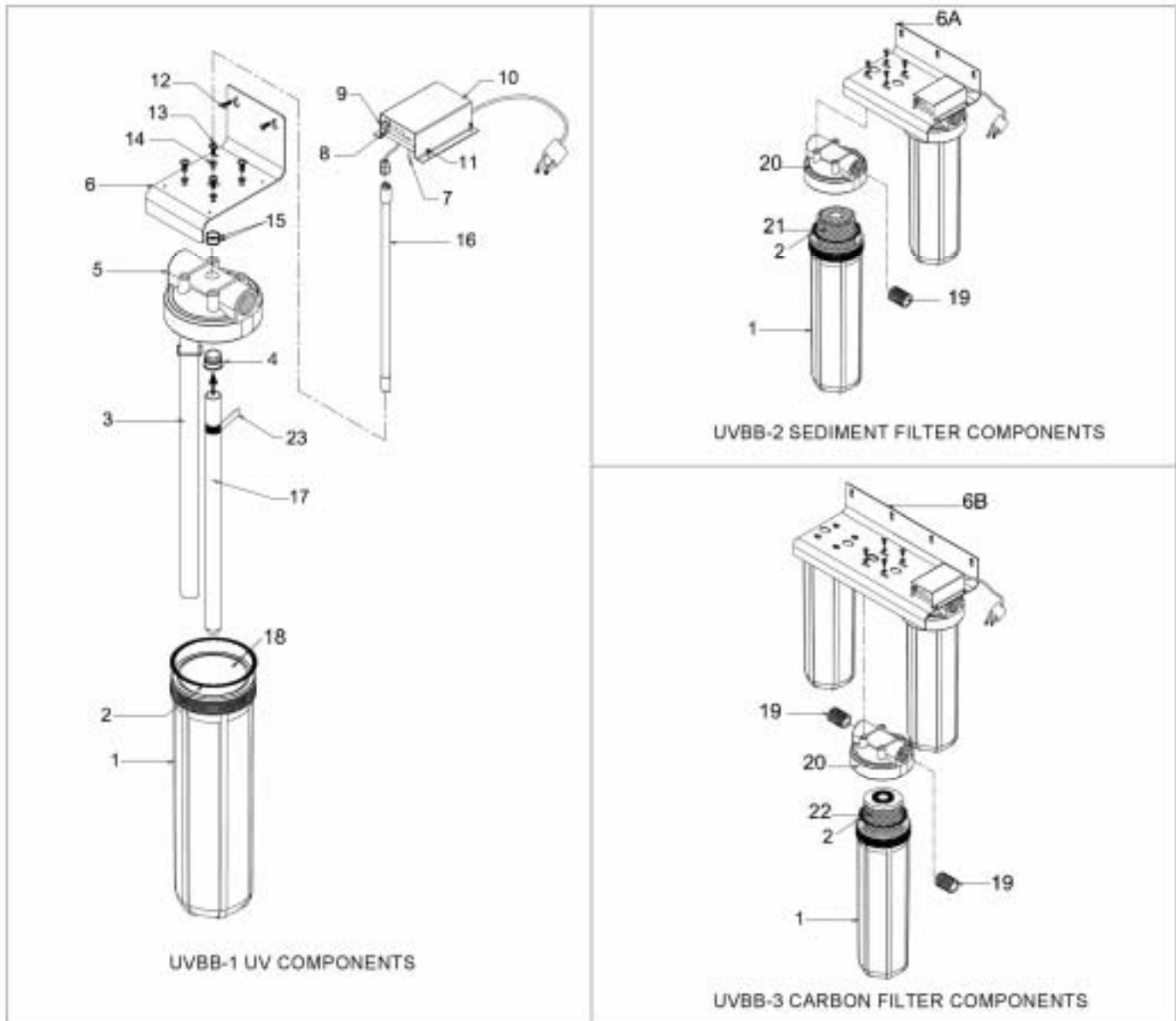

Figure 3 Exploded Schematic, PURA UVBB Series

Parts List - UVBB Series								
Item	Description	Part No.	Item	Description	Part No.	Item	Description	Part No.
1	Sump, UV #20 BB	153070	6A	Mounting Bracket, 2 Sump BB	31910202	15	"O" Ring, Quartz Sleeve BB (2)	34202022
2	"O" Ring, Sump BB	151122	6B	Mounting Bracket, 3 Sump BB	31910302	16	Lamp, UV #20	36002018
3	Sleeve, Teflon, Delivery BB c/w clamp	44301015	7	Switch, Safety	-----	17	Sleeve, Quartz #22 with "O" Rings	36003036
4	Sleeve, Quartz Adapter with "O" Rings	44301009	8	Indicator, LED	-----	18	Sleeve, BB, #20, S/S	36099105
n/s [†]	"O" Ring, Quartz Adapter Sleeve Inner (2 pieces)	34202022	9	Fuse, 1A Type 3AG	31000006	19	Nipple, 1-1/2"	33601024
n/s [†]	"O" Ring, Quartz Adapter Sleeve Outer (2 pieces)	34201039	10	Module, UV Control BB	44302403 [†]	20	Head, Filter 1-1/2" BB	154078
5	Head UV #20 BB, Assy	44303502	11	Screw, 6/32 x 3/8"	32701063	21	Filter, Sediment 20" 5 micron BB	33003117
6	Mounting Bracket, 1 Sump BB	31910102	12	Screw, #14 x 1"	32701060	22	Filter, Carbon Block 20" 10 micron BB, EPM	33004015
			13	Screw, 5/16 x 1-1/4"	32701074	n/s [‡]	Wrench, Sump #20 BB	144368
			14	Washer, 5/16"	32800029	23	Red Tape	-----

[†] Consult Factory to determine part number for applications other than 120V/60hz [‡] not shown

RACK SYSTEM - ASSEMBLY AND INSTALLATION PROCEDURES

PREPARATION - INSPECT ALL PARTS

NOTE: Read Assembly and Installation instructions on this page and UVBB System Installation and Activation Procedures on Page 6 before assembling Rack System.

NOTE: Item numbers in the following table refer to Figures 4 and 5.

Parts List – Rack System		
Item	Description	Qty
1	Feet (18" / 46cm deep)	2
2	Legs (42" / 107cm high)	2
3	Leg Brace (34-1/4" / 87cm wide)	1
4	Corner Braces	4
5	Top (34-1/4" / 87cm wide)	1
6	Lock Nut, 1/4 – 20	22
7	Flat Washer, 1/4"	44
8	Hex Bolt, 1/4 – 20 x 1"	22
9	Flat Washer, 5/16"	16
10	Lag Bolt, 5/16 x 1-1/4"	16
11	Mounting Adapter Plate	1 [†]
12	Screw, 6/32 x 3/8"	4 [†]

[†] Per UV Control Module as specified for applicable configuration.

NOTE: See Page 7 for UVBB detailed parts breakdown. Refer to the label affixed to the UVBB mounting bracket to identify housing units to be installed on rack.

RACK ASSEMBLY

NOTE: Items in this section refer to Figure 4.

CAUTION: Maximum load for the Rack System is 750 lbs. (340 kg). This system is designed for indoor use only.

NOTE: Each UVBB-1 housing assembly can process up to 15 gpm (57 L/min). Up to four assemblies may be installed on the Rack System. Four housing assemblies may be plumbed in parallel (See Figure 6) to obtain a maximum flow of 60 gpm (227 L/min).

NOTE: Each attachment point requires a Bolt (Item 8), two Flat Washers (Item 7), and a Nut (Item 6).

1. Attach the Feet (Item 1) to the bottom of each Leg (Item 2).

NOTE: Snug, but do not tighten the bolts and nuts connecting the legs and top to the Corner Braces (Item 4) until assembly has been squared.

2. Attach two corner braces to the upper end of each leg.
3. Attach the Leg Brace (Item 3) to the back of each leg.
4. Attach the Top (Item 5) to the corner braces.
5. Square top to the legs. Tighten all 16 nuts securing corner braces.

INSTALL UV SYSTEM TO RACK

NOTE: Items in this section refer to Figure 5

NOTE: Figures 5 and 6 provide examples of configurations that may be applied to your PURA system. These configurations are not intended as a representation of a specific system to be installed.

1. Determine location for installation of the Rack System with housing assemblies. Three requirements for consideration are: access to cold water line, access to power, and proper inlet/outlet connection for each housing assembly.

NOTE: Each UV control module has its own cord. A power strip may be required if multiple UV control modules are installed on Rack System.

2. Install the Rack System. Unit may be attached to surface or left freestanding.

3. Secure each Mounting Adapter Plate (Item 11) and UV head to Rack System with Lag Bolts (Item 10) and Flat Washers (Item 9).

NOTE: To install a system in "SERIES" as shown in Figure 5, connect all heads together with nipples prior to installing heads on Rack System.

4. Plumb heads for specific configuration using proper fittings and thread sealing tape.

NOTE: See Page 6 for UVBB Assembly and Activation Procedures to complete installation.

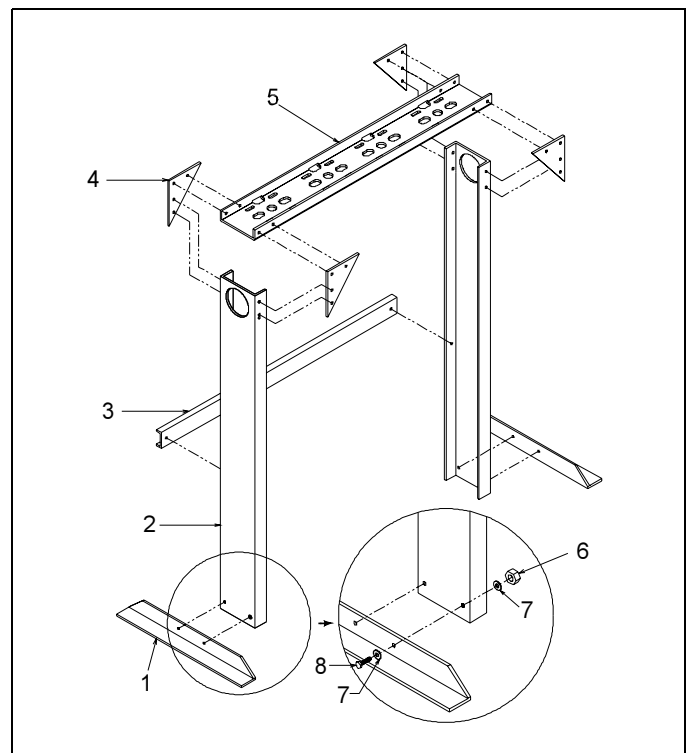

Figure 4: Rack Components and Location

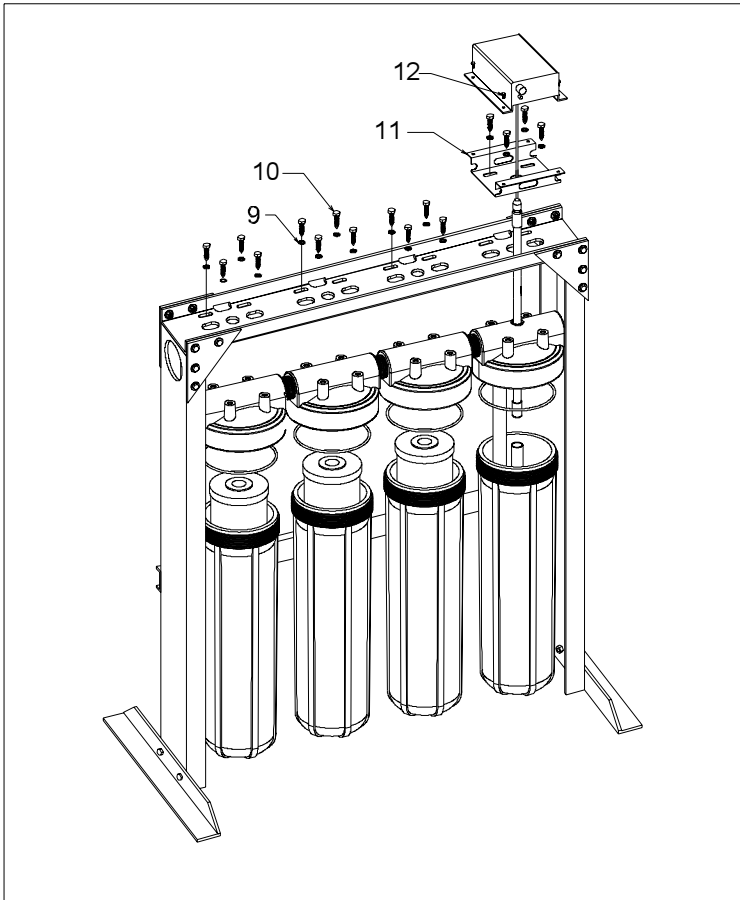

Figure 5: Module Attachment Points

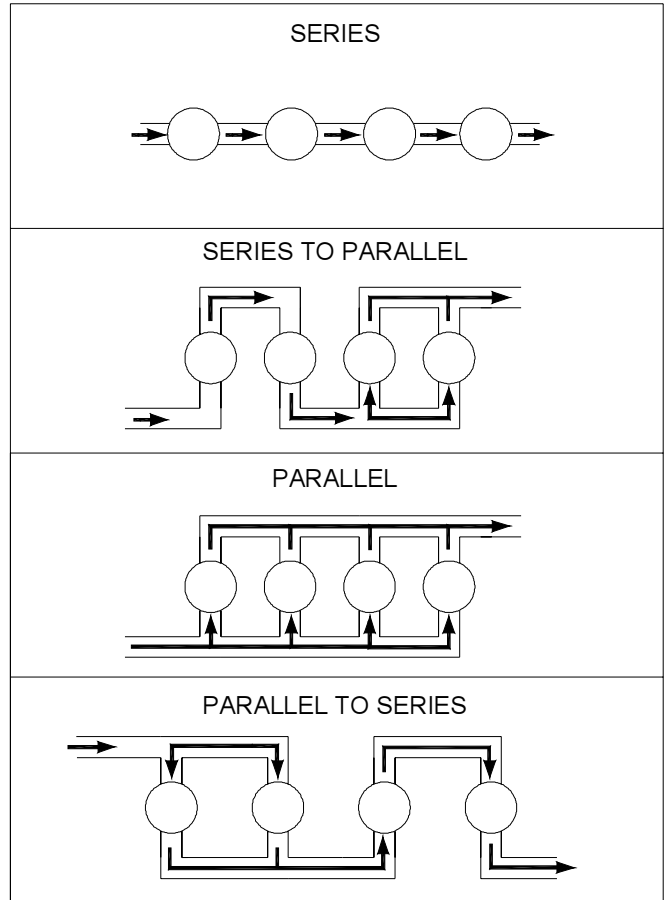

Figure 6: UVBB Rack System Configurations.

DATE INSTALLED	SYSTEM OUTPUT RATING		LPM/GPM
CONFIGURATION:	SERIES <input type="checkbox"/>	SERIES TO PARALLEL <input type="checkbox"/>	PARALLEL <input type="checkbox"/> PARALLEL TO SERIES <input type="checkbox"/>
MODULE #1	TYPE:	PURA PART NUMBER:	
MODULE #2	TYPE:	PURA PART NUMBER:	
MODULE #3	TYPE:	PURA PART NUMBER:	
MODULE #4	TYPE:	PURA PART NUMBER:	

Table 1: System Configuration and Component Parts, Initial Installation

UV1 SERIES - SYSTEM ASSEMBLY AND ACTIVATION PROCEDURE

PREPARATION – INSPECT ALL PARTS

NOTE: Read Mounting Bracket and System Plumbing Installation instructions on Page 1 and all instructions on this page before installing system.

UV1 SERIES
UV1 Ultraviolet System Ultraviolet Lamp #10 (in packing tube) Mounting Screws (2 pieces) Installation Manual and Owners Guide

NOTE: See Page 11 for UV1 detailed parts breakdown. Refer to label affixed to mounting bracket to identify filter to be installed.

DISINFECT SYSTEM

CAUTION: QUARTZ SLEEVE IS VERY FRAGILE!
 For safety, wear a protective glove when handling quartz sleeve. Do not touch quartz sleeve or UV lamp with bare hands. Fingerprints will reduce the effectiveness of the light.

NOTE: Sump wrench not included.

NOTE: Quartz sleeve (Item 14) is factory installed.

NOTE: All Item callouts refer to Figure 7.

1. Remove Sump (Item 1) from UV Head (Item 5).
2. Remove EPCB™ Carbon Filter (Item 3) and EPCB™ Sleeve (Item 15) from sump and set aside.
3. Disinfect the system (Pages 14-15, Steps 1-7).

INSTALL ULTRAVIOLET LIGHT AND FILTERS

1. Remove Sump (Item 1) from UV Head (Item 5).

NOTE: Wipe all fingerprints and excessive lubricant from quartz sleeve with isopropyl alcohol.

2. Install EPCB™ Sleeve (Item 15) into EPCB™ Carbon Filter (Item 3) as shown in Figure 7.
3. Insert filter/sleeve assembly into sump as shown in Figure 7 with both Filter Gaskets (Item 4) in place.

CAUTION: TIGHTEN SUMPS BY HAND ONLY. Do not use tools as they will over-tighten and may damage sump. Take care not to cut or pinch “O” Rings (Item 2).

4. Being careful not to dislodge quartz sleeve, install sump with filter/sleeve assembly onto UV head.

5. Loosen Screw (Item 9) securing slotted side of UV Lamp Retainer (Item 7). Remove the other screw securing the UV lamp retainer to UV head. Rotate UV lamp retainer away from center of UV head.

CAUTION: DO NOT INSTALL A DAMAGED LAMP

NOTE: Hold UV lamp by ceramic ends only. Do not touch the glass. Clean glass with isopropyl alcohol if necessary.

6. Remove the UV Lamp (Item 17) from packing tube and inspect it for damage. If damage is found, contact the dealer for a replacement.

7. Connect UV lamp into the four-pin socket that is connected to the UV Control (Item 11).

8. Carefully insert the UV lamp through mounting bracket into the quartz sleeve as far as possible.

NOTE: End of UV lamp will touch bottom of quartz sleeve.

9. Slide Finish Cap (Item 13) on UV control cable and snap finish cap into Spacer Bushing (Item 12).

10. Rotate UV lamp retainer towards UV lamp such that the retainer will secure the UV lamp. Replace the screw removed in Step 5. Tighten screw loosened in Step 5.

ACTIVATE SYSTEM

CAUTION: Verify that inlet and outlet ports are connected to appropriate inlet/outlet pipes (see Figure 7).

WARNING: NEVER LOOK DIRECTLY AT A LIGHTED UV LAMP. ALWAYS LOOK AT LAMP THROUGH FINISH CAP ONLY.

1. Plug system into an electrical outlet. The finish cap should illuminate within one minute, indicating UV lamp is on. If it does not, unplug system, verify the UV lamp is securely plugged into four-pin socket, and repeat this Step.

NOTE: UV lamp should remain on at all times during use because; repeated starting of UV lamp shortens lamp life, and UV lamp requires a warm up period of 1-2 minutes.

2. Turn on water supply and check for leaks.

3. Flush system, connectors, and water lines for several minutes to remove carbon fines.

NOTE: When an ultraviolet water treatment system is unused for several hours, water within system could become warm. This is a normal condition. To cool the water, dispense water from system.

NOTE: System is now ready for use.

Service Requirements	Recommended Service Intervals
To ensure the system operates at its optimum level, certain routine maintenance must be performed. Frequency of maintenance performance will depend on source water quality and level of system usage. CLEAN: Each time filters are replaced. DISINFECT: At least once a year	UV lamp #10: Change Annually Quartz Sleeve #10: Clean when changing filters. Replace only if damaged or cannot be cleaned by non-abrasive methods. Filter: Normal life 4-6 months. Filter life will vary due to water conditions. A reduced flow rate or deteriorating water quality indicates that filters must be changed.

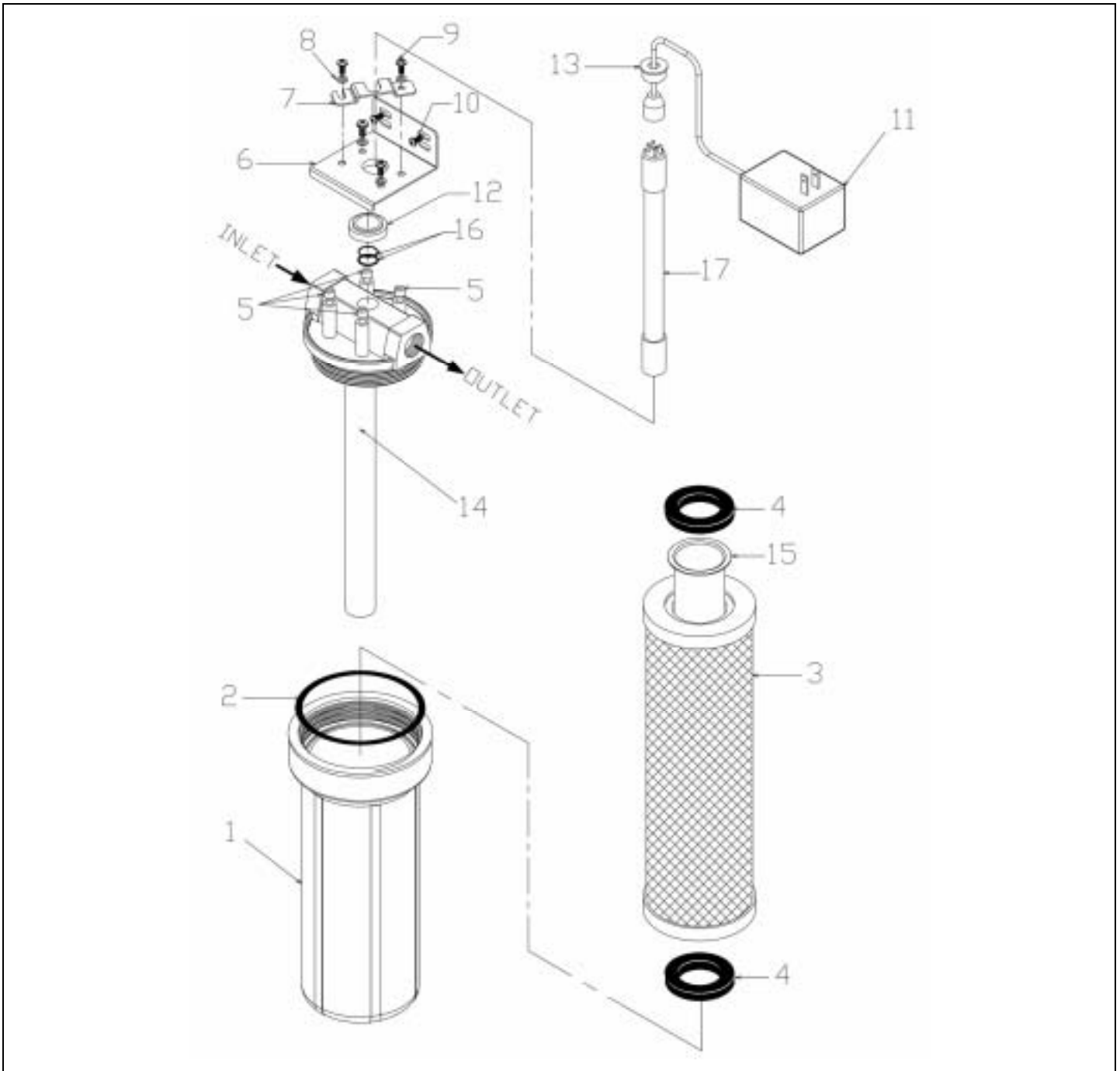

Figure 7 Exploded Schematic, PURA UV1Series

Parts List - UV1 Series								
Item	Description	Part No.	Item	Description	Part No.	Item	Description	Part No.
1	Housing, UV1, Pura*	92500-1	7	Retainer, UV Lamp UV1	31910408	13	Cap, Finish, c/w Control	-----
2	"O" Ring, UV1, Pura	92060	8	Washer, #14 Nylon	32800031	14	Sleeve, Quartz #10 with "O" Rings	36003033
3	Filter, Carbon EPCB™ 10"	33004030	9	Screw, #10-16 x 1"	32701007	15	Sleeve, Teflon	30120506
4	Gasket, c/w Filter	-----	10	Screw, #10 x 3/4"	32701006	16	"O" Ring Quartz Sleeve UV1 (2)	34202020
5	Spacer, UV1, Pura	32701010	11	UV Control, with Finish Cap	40200080 [†]	17	Lamp, UV #10	36002016
6	Mounting Bracket, UV1, Pura	31910107	12	Bushing, Spacer #10 SL	22401017			

[†] Consult Factory to determine part number for applications other than 120V/60hz

*92500-1 includes Items 1, 2, 5, 8, 9 & 16.

ADDON SERIES - SYSTEM ASSEMBLY AND ACTIVATION PROCEDURES

PREPARATION – INSPECT ALL PARTS

NOTE: Read Mounting Bracket and System Plumbing Installation instructions on Page 1 and all instructions on this page before installing system.

ADDON SERIES
Addon Ultraviolet System Ultraviolet Lamp (in packing tube, #10 or #20 varies with model) Quartz Sleeve (in packing tube, only for #20, 3GPM Model) Mounting Screws (2 pieces) Installation Manual and Owners Guide

NOTE: See Page 13 for Addon detailed parts breakdown.

INSTALL QUARTZ SLEEVE (ONLY FOR 3GPM MODEL)

NOTE: Quartz sleeve (Item 13) is factory installed for the 1GPM model only.

NOTE: All Items refer to Figure 8.

CAUTION: QUARTZ SLEEVE IS VERY FRAGILE!

For safety, wear a protective glove when handling quartz sleeve. Do not touch quartz sleeve or UV lamp with bare hands. Fingerprints will reduce effectiveness of the light.

1. Remove Collar (Item 15) from UV Head (Item 5A).

NOTE: Do not remove protective plastic bag from quartz sleeve until so instructed.

2. Remove Quartz Sleeve (Item 13A) from packing tube. While holding middle of quartz sleeve with one hand, slide protective bag with other hand to expose open end.
3. Place a small amount of silicone based “O” ring lubricant on the outside of the open end of the quartz sleeve only on the area that will engage with the “O” ring.

CAUTION: Apply even pressure to push the quartz sleeve into the UV head. To avoid breakage, make sure quartz sleeve goes in straight by pushing it with slight twisting motion.

4. Insert quartz sleeve into the UV head. As quartz sleeve passes both “O” Rings (Item 9), resistance will be felt. Remove protective bag from quartz sleeve.

DISINFECT SYSTEM

CAUTION: TIGHTEN COLLAR BY HAND ONLY. Do not use tools as they will over-tighten and may damage sump. Take care not to cut or pinch Addon Sump Gasket (Item 2).

1. **For ADDON 1GPM Model Only:** Remove Collar (Item 15) from UV Head (Item 5).

NOTE: Wipe all fingerprints and excessive lubricant from quartz sleeve with isopropyl alcohol.

2. Disinfect the system (Pages 14-15, Steps 1-7).

INSTALL ULTRAVIOLET LIGHT

CAUTION: DO NOT INSTALL A DAMAGED LAMP

NOTE: Hold UV lamp by ceramic ends only. Do not touch the glass. Clean glass with isopropyl alcohol if necessary.

1. Remove the UV Lamp (Item 16 or 16A) from packing tube and inspect it for damage. If damage is found, contact the dealer for a replacement.
2. Connect UV lamp into the four-pin socket that is connected to the UV Control (Item 10).
3. Carefully insert the UV lamp through “O” Ring Retainer (Item 11) into the quartz sleeve as far as possible.

NOTE: End of UV lamp will touch the bottom of quartz sleeve.
4. Slide Finish Cap (Item 12) on UV control cable and snap finish cap into “O” Ring Retainer (Item 11).

ACTIVATE SYSTEM

CAUTION: Verify that inlet and outlet ports are connected to appropriate inlet/outlet pipes (see Figure 8).

WARNING: NEVER LOOK DIRECTLY AT A LIGHTED UV LAMP. ALWAYS LOOK AT LAMP THROUGH FINISH CAP ONLY.

1. Plug system into an electrical outlet. The finish cap should illuminate within one minute, indicating UV lamp is on. If it does not, unplug system, verify the UV lamp is securely plugged into four-pin socket, and repeat this Step.

NOTE: UV lamp should remain on at all times during use because; repeated starting of UV lamp shortens lamp life, and UV lamp requires a warm up period of 1-2 minutes.

2. Turn on water supply and check for leaks.
3. Flush system, connectors, and water lines for several minutes to remove carbon fines.

NOTE: When an ultraviolet water treatment system is unused for several hours, water within system could become warm. This is a normal condition. To cool the water, dispense water from system.

NOTE: System is now ready for use.

Service Requirements	Recommended Service Intervals
To ensure the system operates at its optimum level, certain routine maintenance must be performed. Frequency of maintenance performance will depend on source water quality and level of system usage. <p style="text-align: center;">CLEAN: Every 3 to 6 months DISINFECT: At least once a year</p>	UV lamp #10 or #20: Change Annually Quartz Sleeve #11 or #20: Clean when changing lamp. Replace only if damaged or cannot be cleaned by non-abrasive methods.

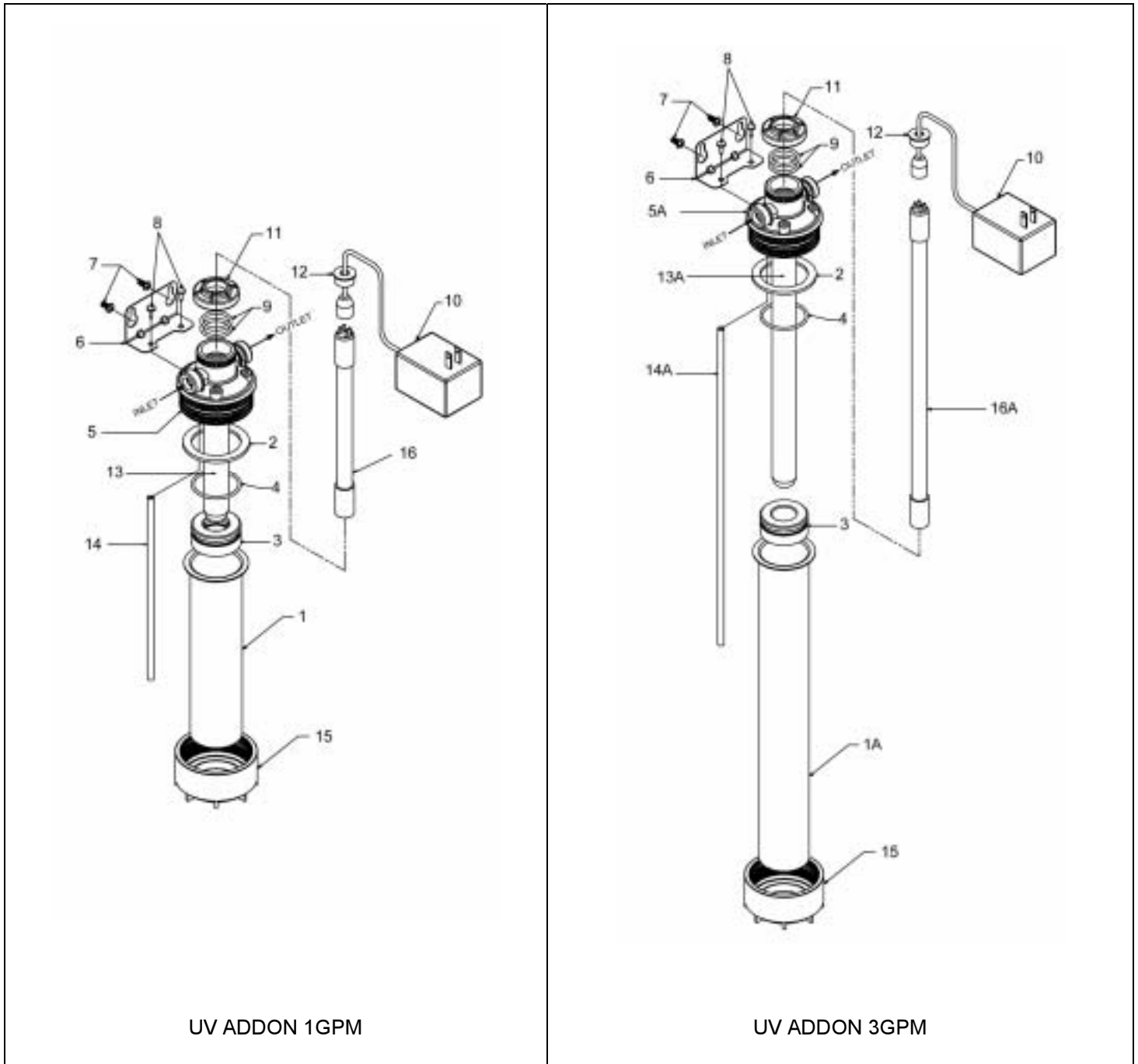

UV ADDON 1GPM

UV ADDON 3GPM

Figure 8 Exploded Schematic PURA ADDON System

Parts List - UV ADDON								
Item	Description	Part No.	Item	Description	Part No.	Item	Description	Part No.
1	Sump, 1gpm Addon	31910007	6	Mounting Bracket, Addon	31910401	13	Sleeve, Quartz #11 with "O" Rings	36003034
1A	Sump, 3gpm Addon	31910006	7	Screw, #10 x 3/4"	32701006	13A	Sleeve, Quartz #20 with "O" Rings	36003035
2	Gasket, Sump Addon	21001004	8	Screw, #10 x 5/8"	00318526	14	Tube, Delivery 1gpm	35817019
3	Plug, Bottom	22401031	9	"O" Ring, Quartz Sleeve Standard (2)	34202021	14A	Tube, Delivery 3gpm	22403202
4	"O" Ring, Bottom Plug	34202037	10	UV Control, with Finish Cap	40200080 [†]	15	Collar, Addon White	22401011 [†]
5	Head, UV Addon White 1gpm	44301002 [†]	11	Retainer, "O" Ring	22401012	16	Lamp, UV #10	36002016
5A	Head, UV Addon White 3gpm	44301005 [†]	12	Cap, Finish, c/w Control	-----	16A	Lamp, UV #20	36002018

[†] Part also available in black [‡] Consult Factory to determine part number for applications other than 120V/60hz

CLEANING, DISINFECTING, AND ROUTINE MAINTENANCE PROCEDURE

RECOMMENDATIONS		
HAVE ALL COMPONENTS ON HAND AND READY BEFORE BEGINNING PROCEDURE A CLEAN WORK AREA AND EQUIPMENT ARE ESSENTIAL TO PROPERLY CLEAN AND/OR DISINFECT THE SYSTEM (i.e., CLEAN HANDS, TOOLS, WORK SURFACE, AND CONTAINERS)		
EQUIPMENT NEEDED		
Safety Glasses Rubber Gloves, Sanitary Wash Cloth, Clean and Lint-Free	Liquid Dish Soap Household Bleach – Unscented Only (5 ¼% Sodium Hypochlorite)	Plastic Bucket “O” Ring Lubricant, Silicone Based
REPLACEMENT FILTERS		REPLACEMENT UV COMPONENTS
Refer to system Parts List for specific component part numbers		Refer to system Parts List for specific component part numbers

CLEANING PROCEDURE

NOTE: Refer to individual System Assembly and Activation Procedures to identify specific components matching the descriptions shown in this procedure.

1. Disconnect system from electrical outlet.
2. Mix a mild cleaning solution of dish soap and clean potable water in the plastic bucket.
3. Close feed water supply valve and open downstream faucet to relieve system pressure.

CAUTION: Do not attempt to remove sumps until water flow stops. This reduces pressure inside the system so sumps may be safely removed.

NOTE: *For UVB and UV1 Models only:* Remove and save Teflon Sleeve as it will be used again with replacement EPCB™ Carbon Filter.

4. Remove each sump. Remove each filter as its sump is removed. Discard the filters. Use sump wrench to remove stubborn sumps.

NOTE: Use sanitary rubber gloves for this procedure to avoid contaminating cleaning solution or filters. Wear gloves whenever cleaning components or handling new filters.

5. Clean quartz sleeve carefully using vinegar to remove hardness. Do not use abrasive materials. Rinse sleeve thoroughly with clean potable water. Replace any sleeve that is damaged or will not come completely clean.
6. Remove sump “O” rings and wash with cleaning solution. Rinse them well with clean potable water. Inspect “O” rings for damage (i.e., nicks or scratches). Replace damaged “O” rings.

CAUTION: Use care when cleaning UV head. Do not get the UV control module or connectors wet.

7. Clean sumps and heads, inside and outside with washcloth and cleaning solution. Do not use abrasive materials.
8. Rinse sumps and heads with clean potable water.
9. *For UV20 Model only:* Clean and rinse the Stainless Steel Channeling Sleeve (Item 3) and Sleeve Gasket (Item 4) shown in Figure 2.

10. Inspect head and sump “O” ring groove area for damage (i.e., nicks or scratches). Replace damaged components.

11. Place a small amount of silicone based “O” ring lubricant on the filter sump “O” ring. Install the “O” ring into the filter sump groove.

DISINFECTION PROCEDURE

CAUTION: WEAR SAFETY GLASSES AND SANITARY RUBBER GLOVES WHILE PERFORMING THIS PROCEDURE.

CAUTION: EXCESSIVE CONCENTRATIONS OF BLEACH WILL DAMAGE PLASTIC AND RUBBER COMPONENTS. Rinse all parts that contact bleach thoroughly with clean potable water.

CAUTION: Read the "WARNINGS" on the bleach container before using.

CAUTION: Handle sanitizing solution carefully. Avoid contact with unprotected areas.

1. Disconnect system from electrical outlet.
2. Mix sanitizing solution:
 - a. *For UVB, UV1, and Addon Models only :* Mix 59 ml (1/4 cup) of household bleach and 177 ml (3/4 cup) of clean, potable water in the bucket. Mix the solution well.
 - b. *For UV20 and UVBB Models only:* Mix 237 ml (1 cup) of household bleach and 237 ml (1 cup) of clean, potable water in the bucket. Mix the solution well.

CAUTION: Use care when sanitizing UV head. Do not get the UV control module or connectors wet.

CAUTION: TIGHTEN SUMPS BY HAND ONLY. Do not use tools as they will over-tighten and may damage sump. Take care not to cut or pinch “O” rings or gaskets. Use sump wrench for removal only.

3. Add sanitizing solution into system:
 - a. *For UVB, UV1, and Addon Models only:* Add 237 ml (1 cup) of sanitizing solution to the sump that contains the UV lamp.
 - b. *For UV20 and UVBB Models only:* Add 473 ml (2 cups) of sanitizing solution to the sump that contains the UV lamp.

- Slowly open the feed water supply valve.
- Open all downstream faucets. Keep faucets open until a chlorine smell is detected at each faucet, then close faucets.

NOTE: Water lines downstream from UV housing must be disinfected to destroy any bacteria that might remain in the pipes.

- Verify disinfection solution has reached every water outlet downstream of UV system. **Solution must remain in the system for at least four hours.**
- Open outlet valve and let water flow for 5 minutes to flush disinfection solution from the water lines.

ROUTINE MAINTENANCE FILTER REPLACEMENT PROCEDURE

- Perform Cleaning Procedure (Page 14, step1-11).

NOTE: Do not remove protective plastic bag from filters. Open bottom of bag only enough to expose bottom of filter.

NOTE: Refer to Exploded Schematic for your system to ensure each filter is installed in the correct position.

NOTE: For UVB and UV1 Models only: Refer to the Exploded Schematic to ensure proper position of Teflon Sleeve removed in Cleaning Procedure.

- Install the filters into the appropriate sump. Hold filter by its protective plastic bag and insert the filter into the sump.

CAUTION: For UVBB Model only: Be sure sump with metal liner is installed onto UV head.

CAUTION: TIGHTEN SUMPS BY HAND ONLY. Do not use tools as they will over-tighten and may damage sump. Take care not to cut or pinch "O" rings or gaskets. Use sump wrench for removal only.

- Slide bag from filter and discard. Replace each sump as each filter is installed.
- Plug system into electrical outlet. Turn on water supply and check for leaks. Flush system for several minutes to remove carbon fines.

ROUTINE MAINTENANCE UV LAMP REPLACEMENT PROCEDURE

NOTE: Refer to individual System Assembly and Activation Procedures to identify specific components matching the descriptions shown in this procedure.

- Disconnect system from electrical outlet.
- Shut feed water supply valve and open downstream faucet to relieve system pressure.

CAUTION: Do not attempt to remove sumps until water flow stops. This reduces pressure inside the system so sumps may be safely removed.

CAUTION: Use care when sanitizing UV head. Do not get the UV control module or connectors wet.

- Remove sump from UV head and set aside.

CAUTION: Do not touch quartz sleeve or UV lamp with bare hands. Fingerprints will reduce the effectiveness of the light.

WARNING: Do Not Attempt to Remove Quartz Sleeve.

Damage to system and personal injury may occur if the sleeve is removed incorrectly. Contact your dealer if quartz sleeve is broken or needs replacement.

- Clean quartz sleeve carefully using vinegar to remove hardness. Do not use abrasive materials. Rinse sleeve thoroughly with clean potable water. Replace any sleeve that is damaged or that will not come completely clean.
 - Gain access to UV lamp:
 - For UVB, UV20, and UVBB Models only.** Remove UV Control Module (Item 10) from Mounting Bracket (Item 6, 6A, 6b) by removing four Screws (Item 11).
 - For UV1 Model only:** Loosen Screw (Item 9) securing slotted side of UV Lamp Retainer (Item 7). Remove other screw securing UV lamp retainer to UV head. Rotate bracket away from UV lamp. Remove and slide Finish Cap (Item 12) on cable towards UV control.
 - Remove UV lamp from system being careful not to break UV lamp or dislodge quartz sleeve:
 - For UVB and UV20 Models only:** Remove UV control module with UV lamp by gently lifting control module straight up from mounting bracket. Grasp UV lamp firmly and remove lamp from the four-pin socket.
 - For UVBB Model only:** Remove UV control module with UV lamp by lifting the control module straight up from mounting bracket. The four-pin socket is attached to the UV control module by a short cable that allows for correct insertion depth. Grasp UV lamp and four-pin socket firmly and separate lamp from connector.
 - For UV1 and Addon Models Only:** Remove UV lamp by gently lifting the cable connecting the four-pin socket to the UV lamp. Grasp UV lamp and four-pin socket firmly and separate lamp from connector. During replacement, be sure UV lamp is inserted as far as possible into the quartz sleeve.
- NOTE:** The inside of quartz sleeve must be completely dry before installing the replacement UV lamp.
- NOTE:** Hold replacement UV lamp by the ceramic ends only. Do not touch the glass. Clean glass with isopropyl alcohol if necessary.
- Install the replacement UV lamp by reversing steps 5 and 6 of this procedure.

PURA® LIMITED WARRANTY

Subject to the conditions and limitations described below, the manufacturer warrants its ultraviolet drinking water systems ("Product") (excluding filters) when installed in accordance with PURA® specifications, to be free from defects in materials and workmanship under normal use within the operating specifications for a period of (3) years from the date of purchase with the exception of the electrical components which are warranted for (1) year. This warranty shall apply only to the original end-user of the Product.

If the Product or any warranted component is found defective, the manufacturer, at its sole option, will repair or replace such Product or warranted component, or will refund all or a pro-rata portion of the Product's purchase price. You pay only freight for repaired or replaced parts from our factory and local dealer charges, including but not limited to labor charges, travel and transportation expenses, and handling fees.

This warranty shall not apply to any part damaged by accident, fire, flood, freezing, Act of God, bacterial attack, filter fouling and/or scaling, sediment, misapplication, neglect, alteration, installation, or operation contrary to our printed instructions, or by use of accessories or components which do not meet PURA specifications. If the drinking water system is modified by anyone other than an authorized PURA dealer, the warranty shall be void.

ALL IMPLIED WARRANTIES, INCLUDING WITHOUT LIMITATION WARRANTIES OF MERCHANTABILITY AND FITNESS FOR PARTICULAR PURPOSE, ARE LIMITED IN DURATION TO THE PERIOD SPECIFIED ABOVE FOR PRODUCT AND COMPONENTS DESCRIBED IN THIS LIMITED WARRANTY.

As a manufacturer, we do not know the characteristics of your water supply. The quality of water supplies may vary seasonally or over a period of time. Your water usage may vary as well. Water characteristics can also change if the Product is moved to a new location. For these reasons, we assume no liability for the determination of the proper equipment necessary to meet your requirements, and we do not authorize others to assume such obligations for us. Further, we assume no liability and extend no warranties, expressed or implied, for the use of this product with a water source that does not meet the Conditions For Use in the Installation Guide & Owner's Manual.

THE MANUFACTURER'S OBLIGATIONS UNDER THIS WARRANTY ARE LIMITED TO THE REPAIR OR REPLACEMENT OF THE FAILED PRODUCT OR COMPONENTS OR THE REFUND OF THE PURCHASE PRICE (AT WATERGROUP'S OPTION), AND WE ASSUME NO LIABILITY WHATSOEVER FOR DIRECT, INDIRECT, INCIDENTAL, CONSEQUENTIAL, SPECIAL, GENERAL, OR OTHER DAMAGES, WHETHER FROM CORROSION OR OTHER CAUSES.

Some states do not allow limitations on how long an implied warranty lasts, so the above limitation may not apply to you. Similarly, some states do not allow exclusion of incidental or consequential damages, so the above limitations or exclusions may not apply to you. This warranty gives you specific legal rights, and you may also have other rights, which vary from state to state. Consult your authorized PURA Dealer for warranty and service information.

WaterGroup Inc.

193 Osborne Road
Fridley, MN
U.S.A. 55432

12350 Philadelphia Street
Mira Loma, CA
U.S.A. 91752

WaterGroup Companies Inc.

580 Park Street
Regina, SK
Canada, S4N 5A9

265 Industrial Road
P.O. Box 5000
Cambridge, ON
Canada N3H 5N3

For parts and service, contact: